

Product Data Sheet

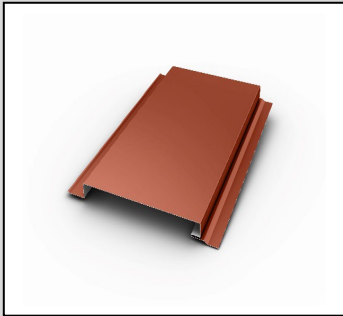

DefendEX™ SP1000R

Metal Paneling

Soffit And Fascia Panel

Description

DefendEX™ SP1000R (SP1000R) is a factory-formed, interlocking, architectural metal panel designed for soffit and fascia applications. SP1000R offers the design professional a flush or flat appearance by utilizing an interlocking leg and concealed fastening system. The panel is available in a wide variety of materials and finishes including Kynar®-coated galvanized steel, Zinalume®/Galvalume® Steel, Copper and Aluminum.

Method of Application

1. A smooth, solid substrate of plywood, OSB, or a substructure of min 22 ga (0.79 mm), 7/8 in. (22 mm) hat channels is recommended for the DefendEX SP1000R.
2. DefendEX SP1000R must be installed in a sequential order.
3. Prior to panel installation, application of an approved underlayment is required.

Storage

- DefendEX metal panels should be stored in a well-ventilated, dry location, where no moisture can contact them. Moisture (From rain, snow, condensation, etc.) trapped between layers of material may cause water stains or white rust, which can affect the service life of the material and will detract from the appearance.
- If outdoor storage cannot be avoided, protect the panels with a ventilated canvas or waterproof paper cover. Do not use plastic, which can cause condensation. Keep the material off the ground in an inclined position with an insulator such as wood, or keep panels crated.
- Storage of end-use materials with protective film applied to the surface should be:
 - Wrapped/packaged to prevent exposure to direct UV, water, oils, or other contaminants.
 - Stored in an enclosed building or holding facility.
 - Within a temperature range of 45° - 90° F (7° - 32° C) and 20 - 80% relative humidity.
 - Less than six months with masking applied (warehouse storage and outdoor exposure combined).
 - Protective film may become brittle with long-term UV exposure.

Precautions

- Oil canning is not a cause for rejection.
 - Heavier gauges, narrower widths, striations, and embossing minimize oil canning.
- Sealant for end laps and lap joints shall be non-drying, non-toxic, and non-shrinking with a serviceable temperature of -60° - 212° F (-51° - 100° C).
- Quality, long-life butyl sealants work best as a gasket sandwiched between two pieces of metal. Non-acetic cured, silicone, color-matching sealants are recommended when voids must be filled. Sealants are not a substitute for proper assembly and workmanship.
- Exercise caution when handling to avoid injury or product damage.
- Refer to Safety Data Sheets (SDS) for safety information.
- **Immediately remove protective film after installation.**

Manufacturing Location: Anoka, MN



Product Data	
Property	Value
Panel Type	Flush with Reveal Joint
Panel Interlock	Interlocking Joint
Taper Panels	No
Radius Panels	No
Stiffening Ribs	Optional
Striations	Optional as SP1000R
Sealant	No
Substrate	Solid Substrate or Hat Channels
Standard Panel Surface	Smooth
Optional Panel Surface	Stucco Embossed

This sheet is meant to highlight Exceptional Metals products and specifications and is subject to change without notice. Amrize™ takes responsibility for furnishing quality materials that meet published Exceptional Metals product specifications or other technical documents, subject to normal manufacturing tolerances. Neither Amrize nor its representatives practice architecture. Amrize offers no opinion on and expressly refuses any responsibility for the soundness of any structure. Amrize accepts no liability for structural failure or resultant damages. Consult a competent structural engineer prior to installation if the structural soundness or structural ability to properly support a planned installation is in question. No Amrize representative is authorized to vary this disclaimer.

Product Size	
Property	Value
Panel Depth	1 in. (25.4 mm)
Seam Height	1.1 in. (29 mm)
Minimum Panel Length	36 in. (914.4 mm)
Maximum Panel Length	600 in (15.24 m)

Technical Information	
Property	Value
Fire Rating	UL Class A Rated Assemblies, UL 263, and UL 790
Hail Impact Rating	UL 2218, Class 4

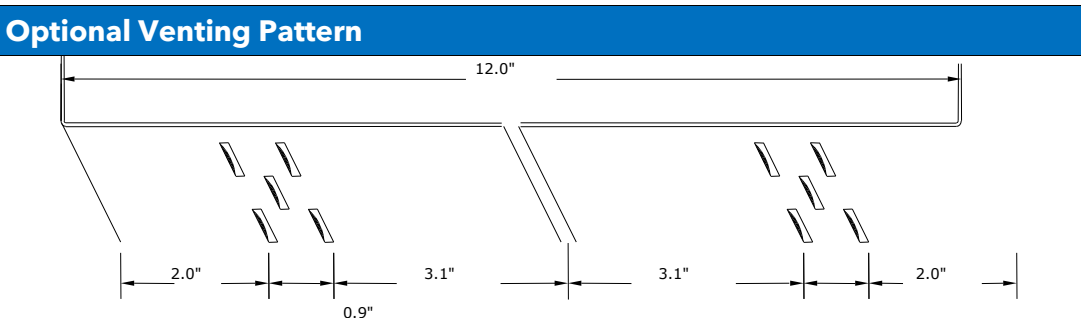

Typical Properties		
Material and Thickness	Metal Specification	Available Finishes
<u>Aluminum</u> 0.032 in. (0.81 mm) 0.040 in. (1.02 mm)	Base Metal: Aluminum Minimum Yield: 21 KSI (145 MPa) Thermal Expansion: 12.6 x 10 ⁻⁶ in/in/ °F (22.68 x 10 ⁻⁶ mm/mm/°C) Modulus of Elasticity: 10.0 x 10 ³ x KSI (68.9 MPa)	Anodized Kynar 500®/Hylar 5000® Unpainted/Mill Finish
<u>Zincalume/Galvalume Steel</u> 26 ga (0.48 mm) 24 ga (0.64 mm) 22 ga (0.79 mm)	Base Metal: AZ-50 Hot Dipped Galvalume Minimum Yield: 50 KSI (345 MPa) Thermal Expansion: 6.7 x 10 ⁻⁶ in/in/ °F (12.06 x 10 ⁻⁶ mm/mm/°C) Modulus of Elasticity: 29.0 x 10 ⁶ x KSI (200 GPa)	Zincalume Plus/ Galvalume Plus/ Acrylume® - Clear Acrylic Coated Kynar 500/Hylar 5000
<u>AGSC Copper</u> 16 oz (0.56 mm) 20 oz (0.69 mm)	Minimum content: 99.9% copper, silver counting as copper, cold rolled from ingots of 122 alloy. Thermal Expansion: 9.3 x 10 ⁻⁶ in/in/ °F (1.674 x 10 ⁻⁵ mm/mm/°C) Meets and/ or exceeds ASTM B370 specification.	Natural

NOTE: Consult the appropriate base metal sheet and coil product data sheet for additional information on the base metal and coating. Not all materials and thicknesses are available from all locations.

Contact Exceptional Metals Technical Services at (866) 337-4599 for further information.

EXCEPTIONAL Metals is a brand of Amrize Building Envelope LLC.
"EXCEPTIONAL", "DefendEX", and Amrize are trademarks in the Amrize portfolio. All other trademarks are property of their respective owners.